

# **CARTRIDGE SEAL INSTALLATION**

# **CARTRIDGE SEAL INSTALLATION**

- **CHECK PUMP SHAFT FOR BURRS**
- **CHECK GLAND BOSS FOR NICKS**
- **LUBRICATE SECONDARY SEALS**
- **SLIDE SEAL ONTO PUMP SHAFT**
- **ASSEMBLE PUMP COMPONENTS**
- **SET IMPELLER CLEARANCE**
- **BOLT UP SEAL GLAND**
- **TIGHTEN SET SCREWS AND PULL TABS**

# **CARTRIDGE SEAL INSTALLATION**

- **BURRS ON THE PUMP SHAFT COULD CUT SHAFT/SLEEVE O-RINGS WHEN INSTALLING THE SEAL RESULTING IN LEAKAGE**
- **NICKS OR ANY OTHER IRREGULARITY ON THE GLAND BOSS COULD RESULT IN IMPROPER SEALING OF THE GLAND GASKET/O-RING**

# CHECKING SHAFT AND GLAND BOSS FOR BURRS, NICKS OR OTHER IRREGULARITY

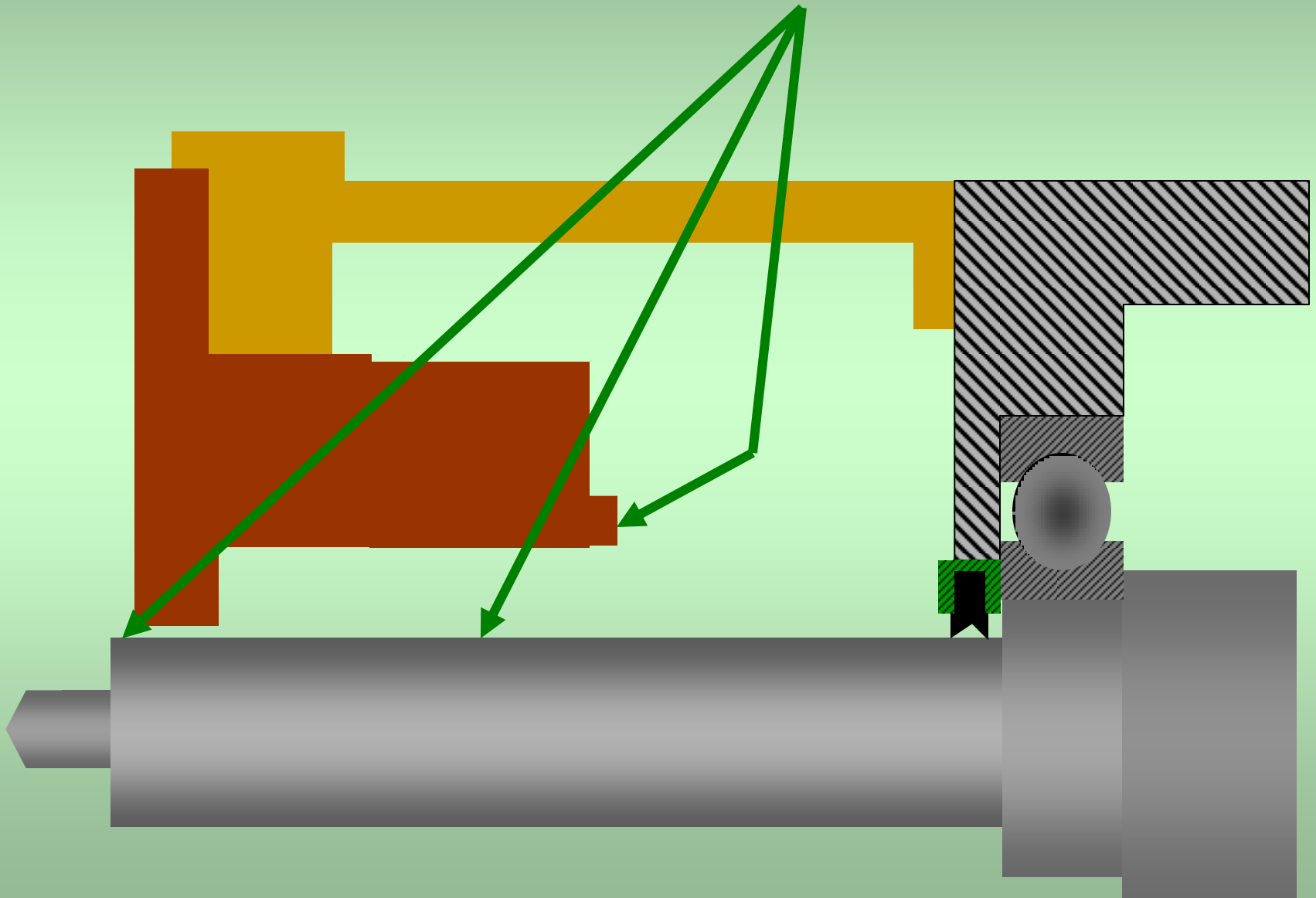

# **CARTRIDGE SEAL INSTALLATION**

- **LUBRICATE O-RINGS/GASKETS SO THAT THEY DON'T HANG UP, TEAR OR "ROLL OUT" WHEN SLIDING THE SEAL ONTO THE PUMP SHAFT**
- **LUBRICATING THE GLAND O-RING WILL PREVENT IT FROM FALLING OUT OF THE O-RING GROOVE BEFORE BOLTING UP THE GLAND**

# CARTRIDGE SEAL INSTALLATION

- GENTLY SLIDE THE SEAL ASSEMBLY ONTO THE PUMP SHAFT UNTIL THE SHAFT/SLEEVE O-RING IS RESISTING
- APPLY EVEN PRESSURE TO THE END OF THE SEAL SLEEVE UNTIL THE SHAFT/SLEEVE O-RING SLIDES ONTO THE PUMP SHAFT
- ASSEMBLE THE REMAINING PUMP COMPONENTS TAKING CARE NOT TO IMPACT THE SEAL ASSEMBLY

# CARTRIDGE SEAL INSTALLATION

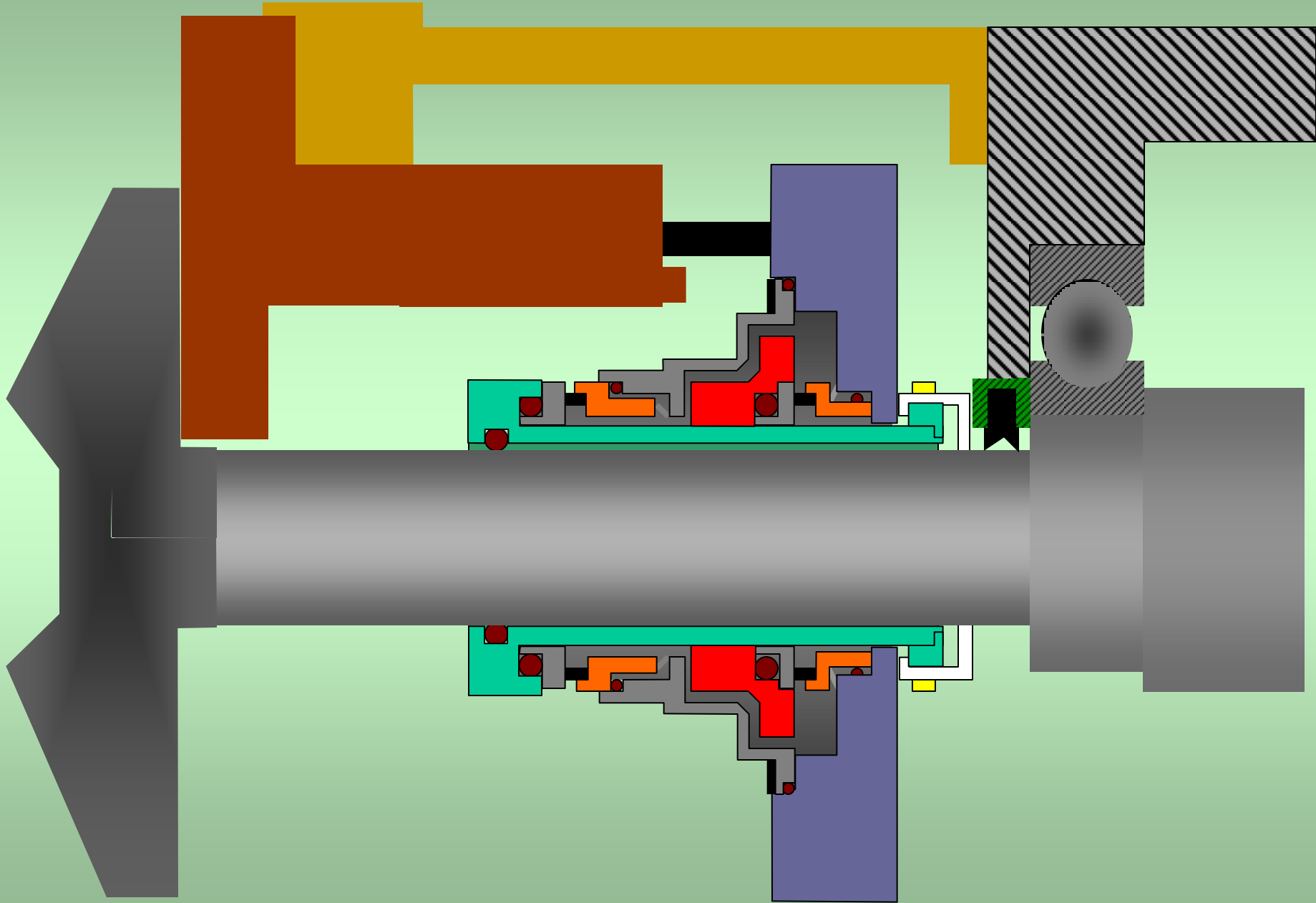

# CARTRIDGE SEAL INSTALLATION

- ONCE ALL PUMP COMPONENTS ARE ASSEMBLED, SET IMPELLER CLEARANCE. DO NOT SET IMPELLER CLEARANCE AFTER THE SEAL HAS BEEN BOLTED UP AND SET
- CHECK GLAND ORIENTATION REQUIREMENTS AND BOLT UP THE GLAND ACCORDINGLY



# CARTRIDGE SEAL INSTALLATION

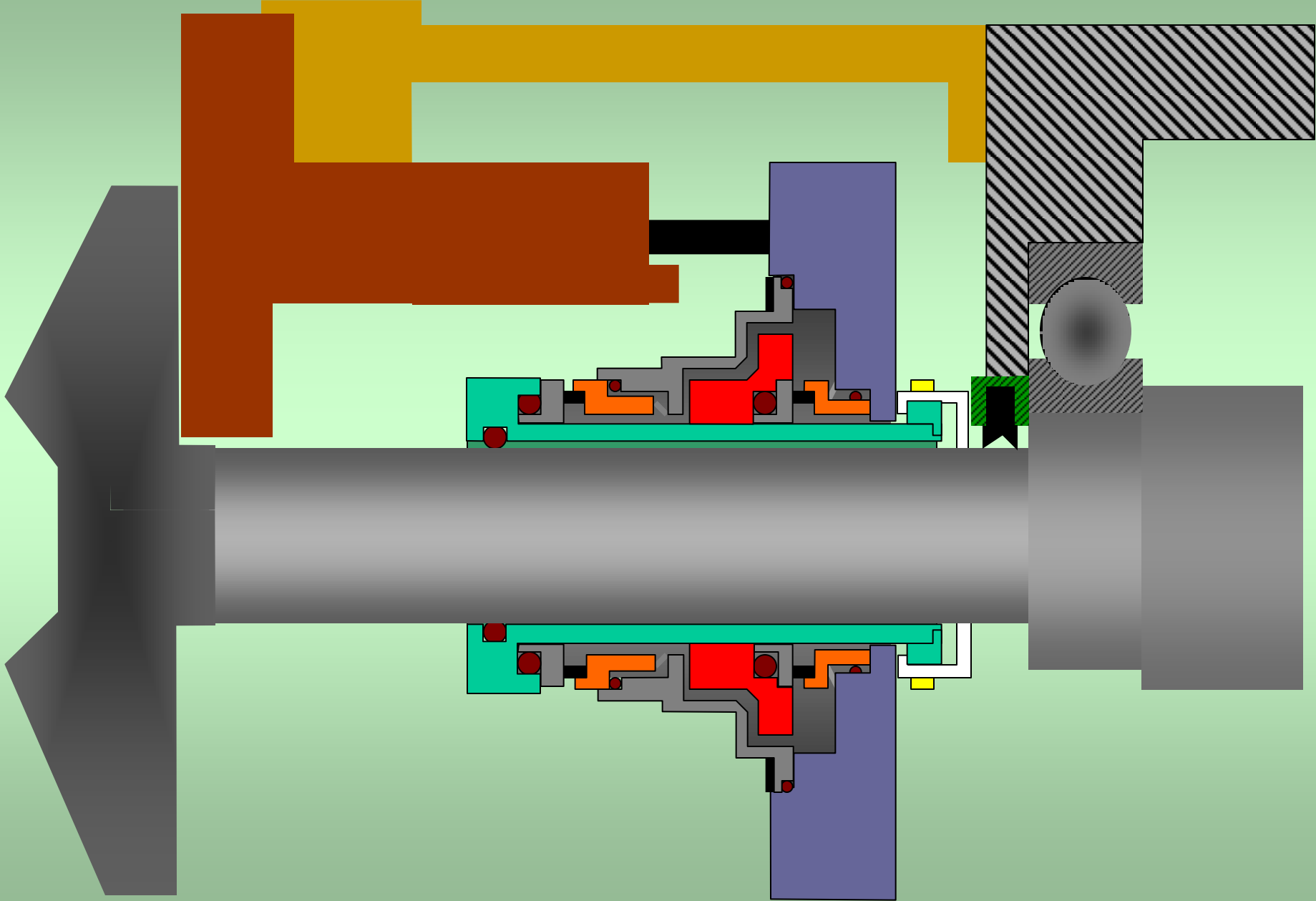

# CARTRIDGE SEAL INSTALLATION

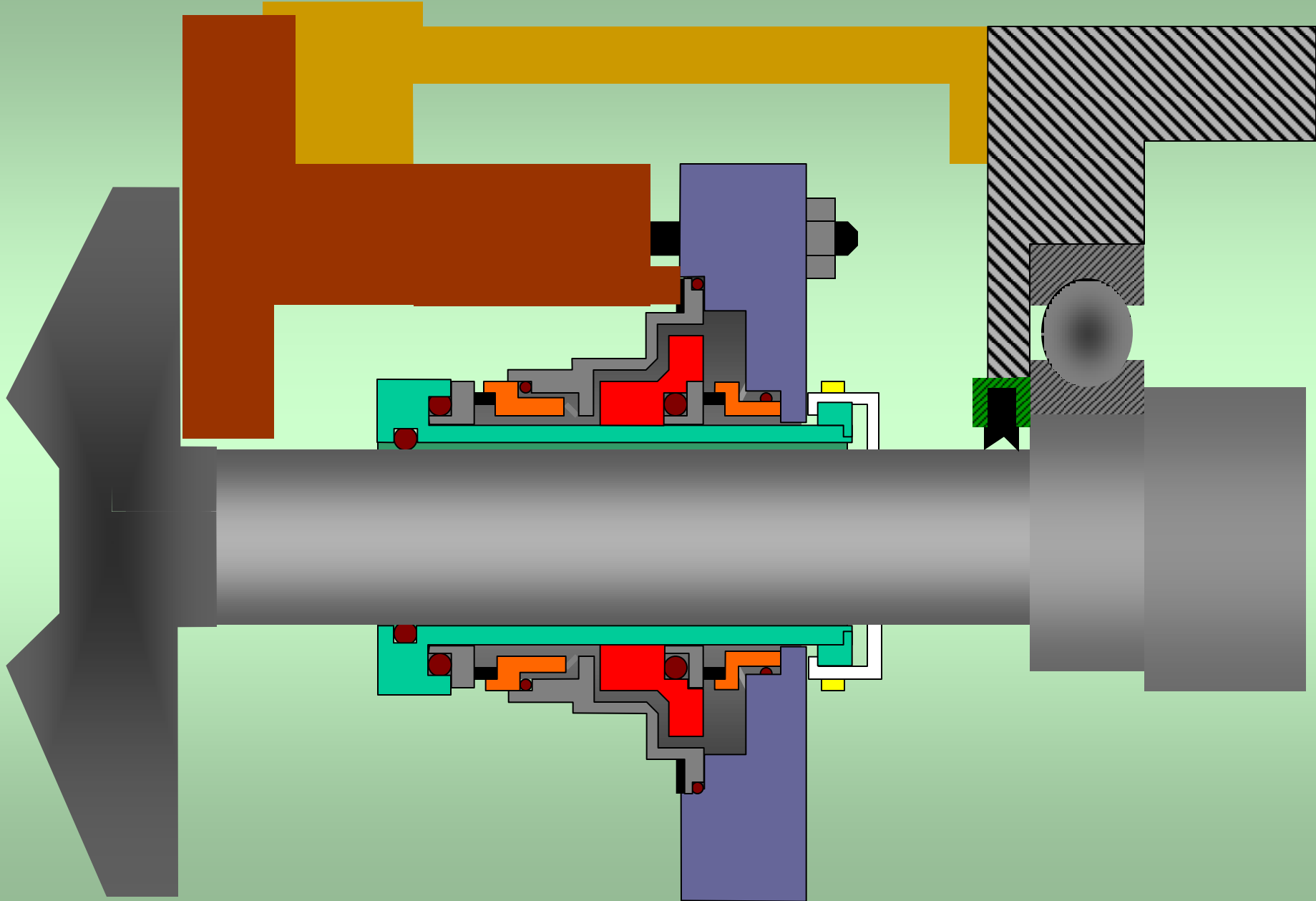

# CARTRIDGE SEAL INSTALLATION

- TIGHTEN ONE SET SCREW UNTIL IT TOUCHES THE PUMP SHAFT LIGHTLY
- MOVE TO THE OPPOSITE SET SCREW AND TIGHTEN IT FULLY
- FULLY TIGHTEN ALL SET SCREWS
- REMOVE SET TABS
- IF THE PUMP IS TO BE STORED WITH A SEAL INSTALLED, DO NOT TIGHTEN SET SCREWS OR REMOVE SET TABS

# CARTRIDGE SEAL INSTALLATION

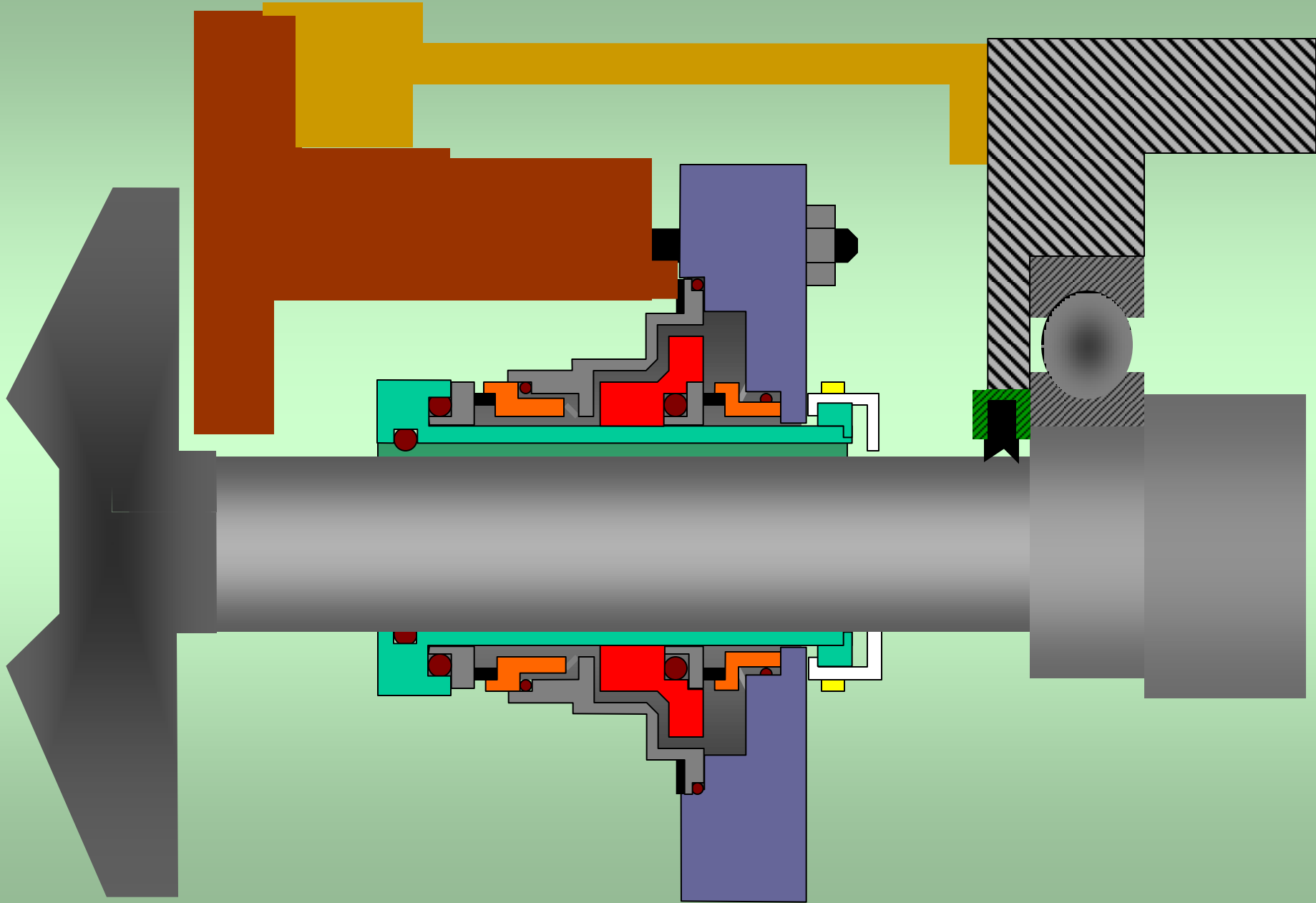

# CARTRIDGE SEAL INSTALLATION

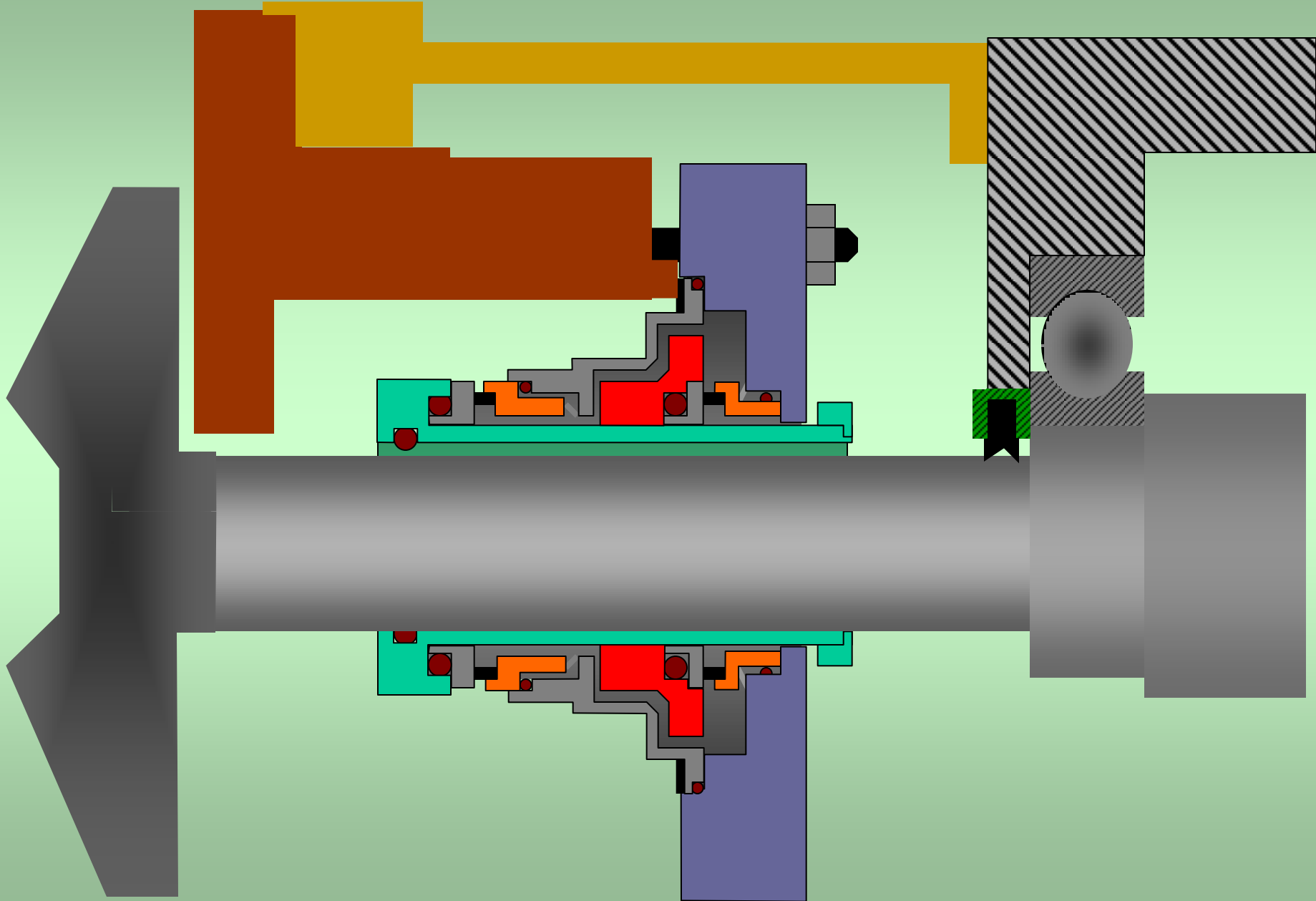

# STORING ASSEMBLED PUMP

- IF THE PUMP IS TO BE PLACED IN STORES WITH A CARTRIDGE SEAL PRE-INSTALLED, DO NOT TIGHTEN GLAND BOLTS OR SET SCREWS
- LEAVE GLAND BOLTS HAND TIGHT AND DO NOT REMOVE SET TABS
  - If gland orientation does not match up with piping configuration in the “Unit”, the seal can be rotated without disturbing seal faces

**END  
CARTRIDGE SEAL  
INSTALLATION**